

## Torque ScrewDriver

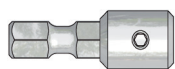

Adapter

Typ	Colour Code	Sector
DMS 2	green	2 Ncm
DMS 3	blue	3 Ncm
DMS 4	red	4 Ncm

## Crimp Tool AFM8

- ▶ 4 point crimping
- ▶ For receptacles
- ▶ Crimping capacities adjustable

### Technical Data

Wire Size	0.09 - 0.82 mm <sup>2</sup>
AWG	32 - 20
Weight	332,75 g

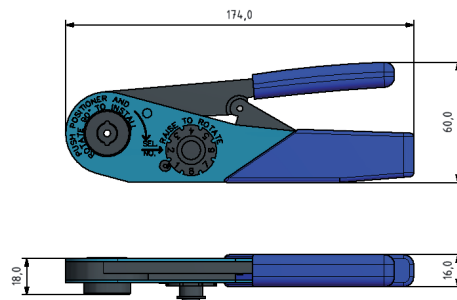

## Digital Force Gauge FKT 50

### Specifications

Display	5-digits LCD display with light
Display Direction	Positive or Reserve direction, select by the push button on the front panel
Function	Tension & Compression (Push & Pull)
Peak hold	Will freeze the display value of the peak load (Max. load)
Zero	Zero button can be operated both for "normal force" or Peak hold" operation
Unit select	g / N / oz
Measure Capacity	5 kg / 49,3 N / 176,40 oz
min. Display	3 g / 0,03 N / 0,10 oz
Accuracy	+/-0,4% bei 25 °C
Overload Capacity	7,5 kg
Power Consumption	Approx. 28 mA
Power Supply	6 x 1,5 V AA (not included)
Dimension	215 x 90 x 45 mm
Weight	650 g with batteries



### Dimension

Ø A mm	Ø B mm	Center mm
2.1	1.6	2.54
2.6	2.1	2.54
3.6	3.1	4.0
4.6	4.1	5.0
5.6	5.1	6.0

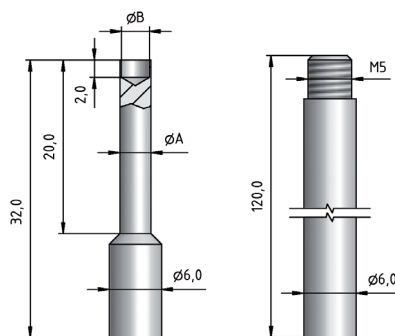

Test Point

Connecting Bar